

Identifying Design Principles

Maneesh Agrawala

CS 294-10: Visualization
Fall 2007

Final project

Design new visualization method

- Pose problem, Implement creative solution

Deliverables

- Implementation of solution
- 8-12 page paper in format of conference paper submission
- 2 design discussion presentations

Schedule

- Project proposal: 10/24
- Initial problem presentation: 10/24, 10/29 or 10/31
- Midpoint design discussion: 11/19, 11/21 or 11/26
- Final paper and presentation: To be determined

Grading

- Groups of up to 3 people, graded individually
- Clearly report responsibilities of each member

Identifying Design Principles

Good Design Improves Effectiveness



London Underground [Beck 33]

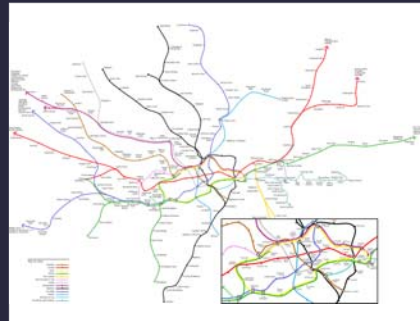

Geographic version of map

Good Design Improves Effectiveness



London Underground [Beck 33]

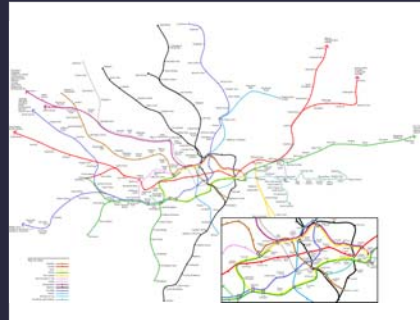

Geographic version of map

Design principle:

- Straighten lines to emphasize sequence of stops

Technique used to emphasize/de-emphasize information

Approach

Identify design principles

- Cognition and perception

Instantiate design principles

- Principles become constraints that guide an optimization process



Route maps

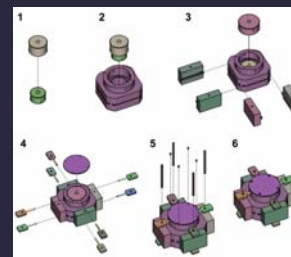

Assembly instructions

Design Principles

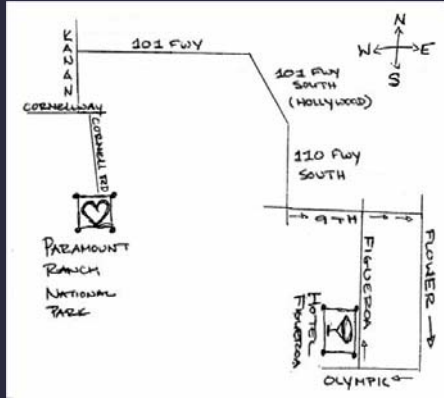

- Exaggerate road length
- Regularize turning angles
- Simplify road shape

LineDrive

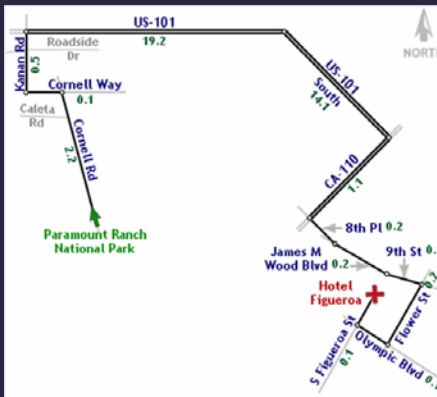
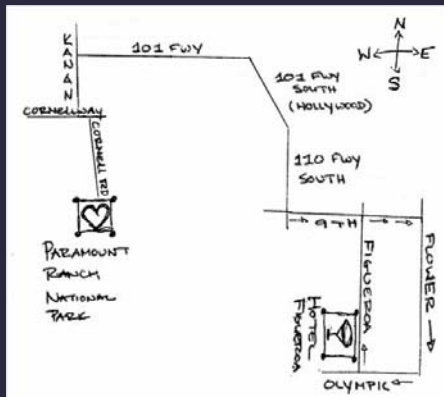

Hand-drawn route map

LineDrive route map

Map Design via Optimization

Set of graphic elements

- Roads, labels, cross-streets, ...

Choose visual attributes

- Position, orientation, size, ...
- Distortions increase flexibility

Develop constraints based on design principles

Simulated annealing

- Perturb: Form a layout
- Score: Evaluate quality
- Minimize score

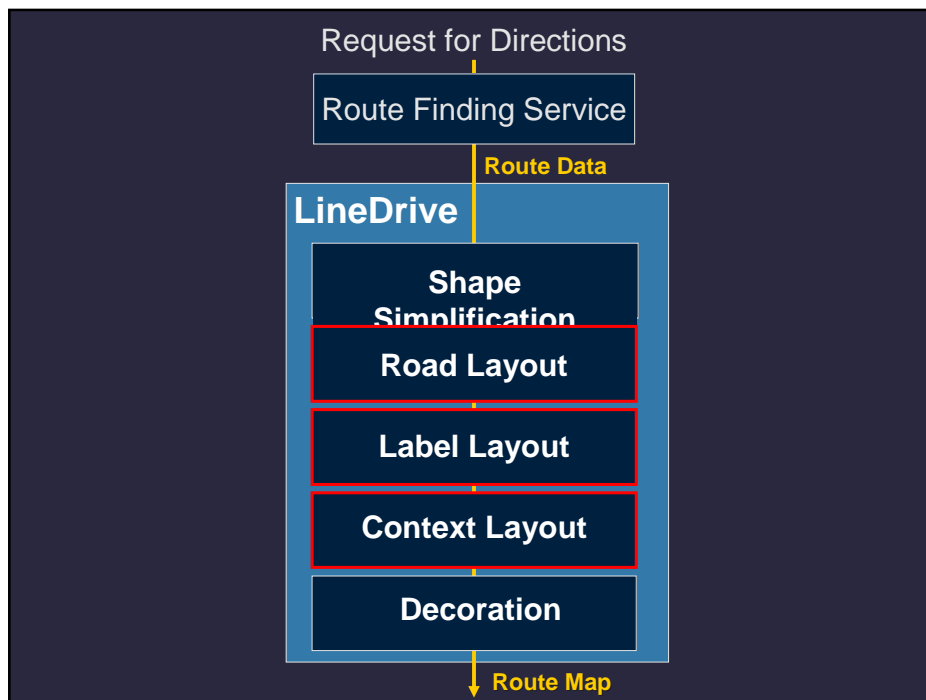
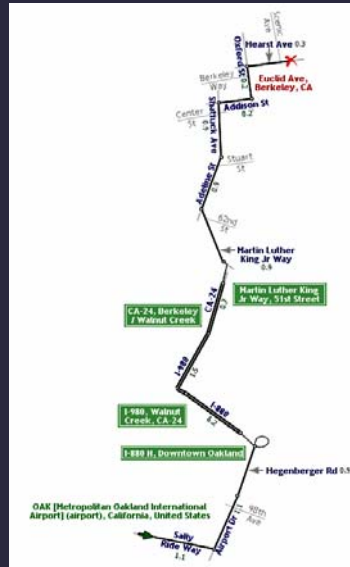

Road Layout

Choose road lengths and orientations

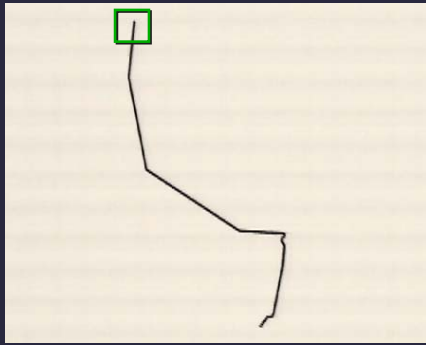

Before road layout

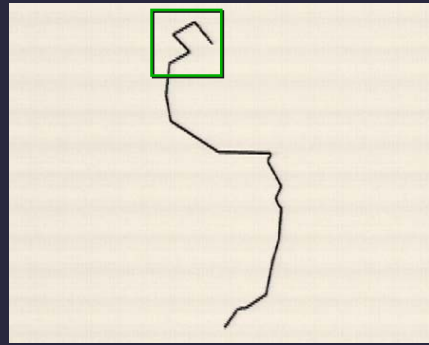

After road layout

Road Layout

Choose road lengths and orientations

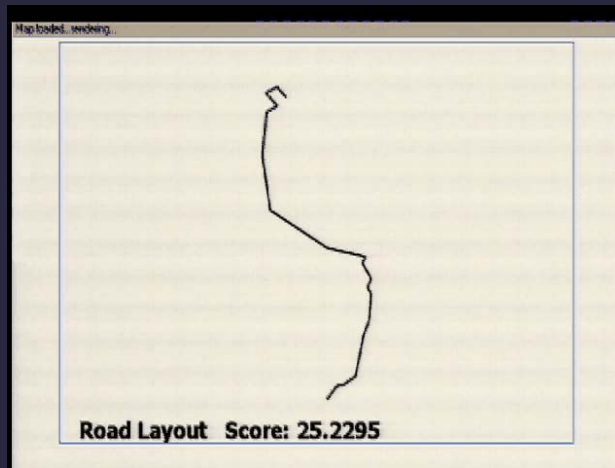

Road Layout Constraints

Length

Ensure all roads visible $((L_{\min} - l(r_i)) / L_{\min})^2 * W_{\text{small}}$

Maintain ordering by length W_{shuffle}

Orientation

Maintain original orientation $|\alpha_{\text{curr}}(r_i) - \alpha_{\text{orig}}(r_i)|^*$
 W_{orient}

Topological errors

Prevent false W_{false} $\min(d_{\text{origin}}, d_{\text{dest}})^*$

Prevent missing $d * W_{\text{missing}}$

Ensure separation W_{ext} $\min(d_{\text{ext}}, E)^*$

Overall route shape

Balancing the Constraints

Prioritize scores by importance

1. Prevent topological errors
2. Ensure all roads visible
3. Maintain original orientation
4. Maintain ordering by length
5. Maintain overall route shape

Priorities set based on usability tests

- Users given maps containing errors
- Rated which errors most confusing

Label Layout

Find overlap-free position for each label

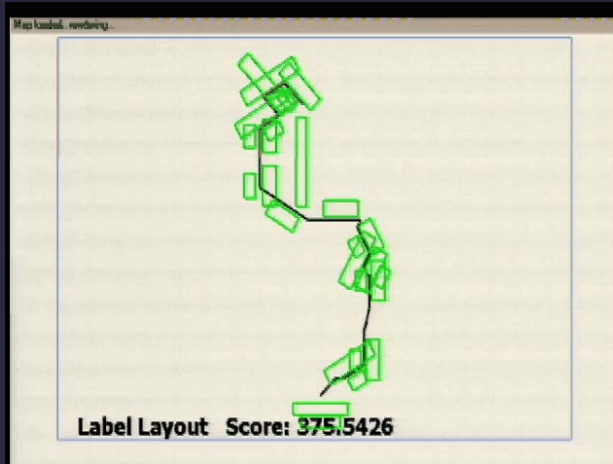

Context Layout

Place cross-streets and exit signs if possible

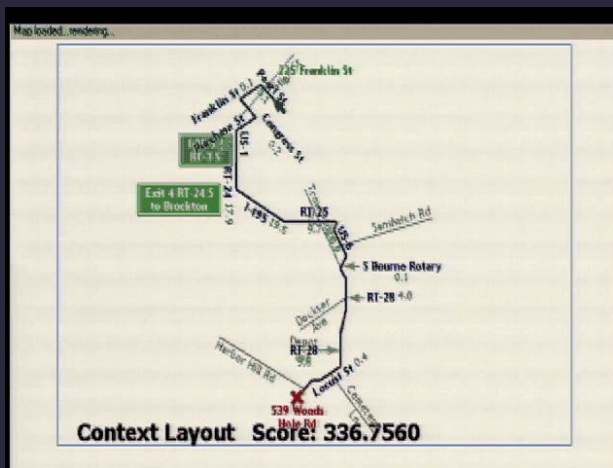

Bellevue to Seattle



Cross-Country Route

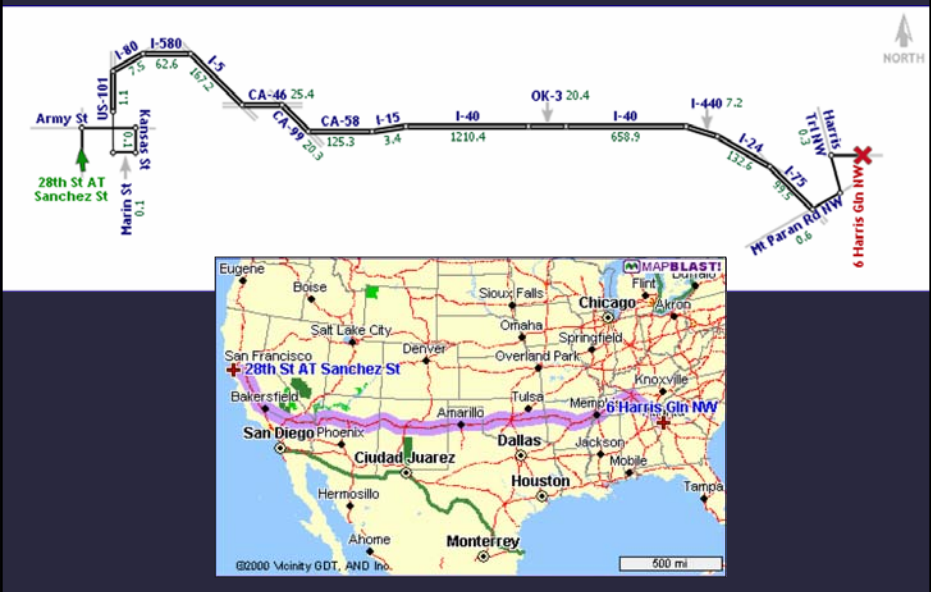

System Performance

7727 routes (sampled over 1 day at MapBlast!)

■ Median distance	52.5 miles
■ Median number turning points	13
■ Median computation time	0.7 sec
■ Short roads	5.4 %
■ False intersections	0.3 %
■ Missing intersections	0.2 %
■ Label-label overlap	0.5 %
■ Label-road overlap	11.7 %

Results

Beta version 6 months

- 150,000 maps served

2242 responses

■ Replace standard	55.6 %
■ Use with standard	43.5 %
■ Prefer standard	0.9 %

Current Status

- Deployed at: mappoint.com
- 750,000 maps/day

Start: Oakland (Metropolitan Oakland International Airport) (airport), California, United States
 End: Euclid Ave, Berkeley, CA 94709
 Total Distance: 12.1 Miles
 Estimated Total Time: 24 minutes

Directions	Miles
Start: Depart OAK (Metropolitan Oakland International Airport) (airport), California, United States on Baly Rd/Euclid Ave (East)	1.0
1: Turn LEFT (North) onto Airport Dr	1.0
2: Turn RIGHT (North) onto Heegenberger Rd	0.8
3: Bear RIGHT (North-West) onto ramp	0.2
4: Continue (North-West) on I-880/Nimitz Fwy	6.1
5: Continue (North) on I-880	1.5
6: Continue (North) on CA-24/Grove Shafter Fwy	0.7
7: Continue (North) on ramp	0.7
8: Bear RIGHT (North) onto Martin Luther King Jr Way	0.8
9: Turn RIGHT (North) onto Adeline St	0.8
10: Bear RIGHT (North) onto Shattuck Ave	0.8
11: Turn RIGHT (East) onto Addison St	0.1
12: Turn LEFT (North) onto Oxford St	0.2
13: Turn RIGHT (East) onto Hearst Ave	0.9
End: Arrive Euclid Ave, Berkeley, CA 94709	

DEMO

mappoint.com

Limited Resolution PDA

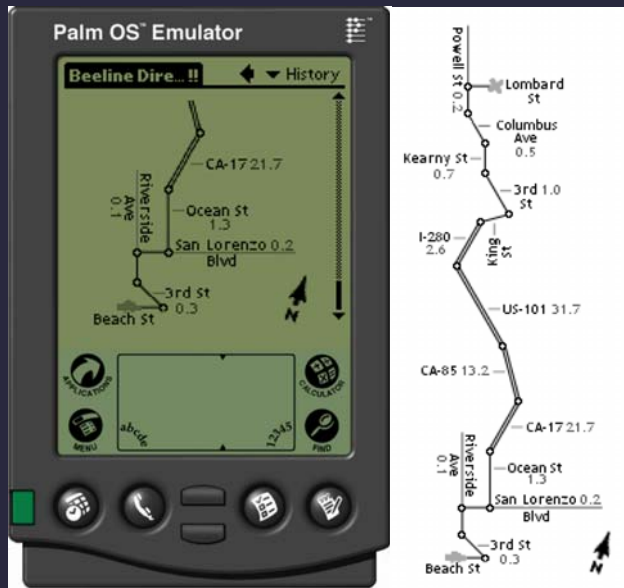

Assembly Instructions

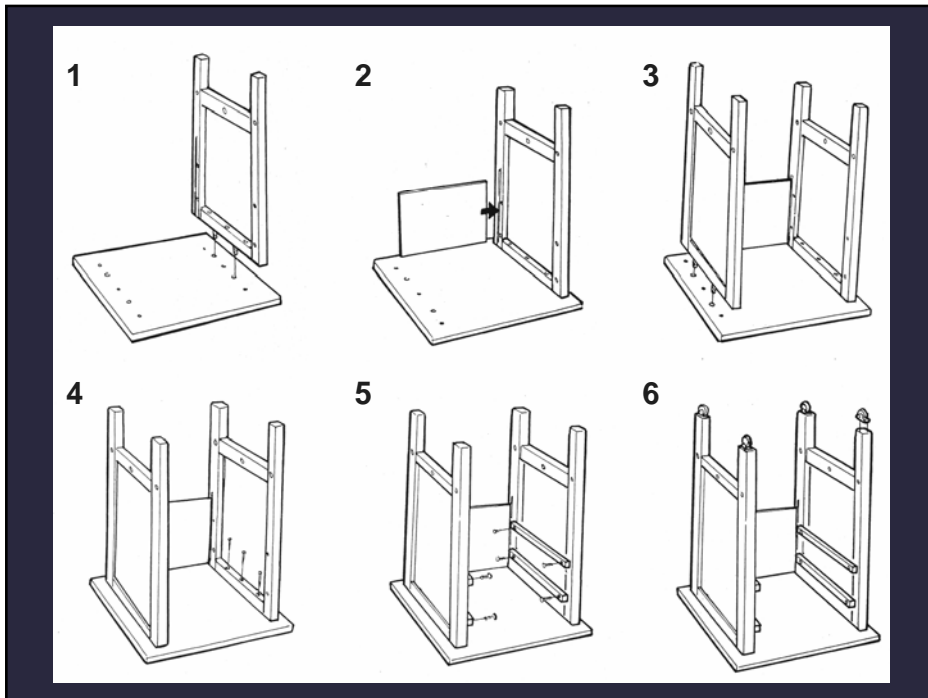

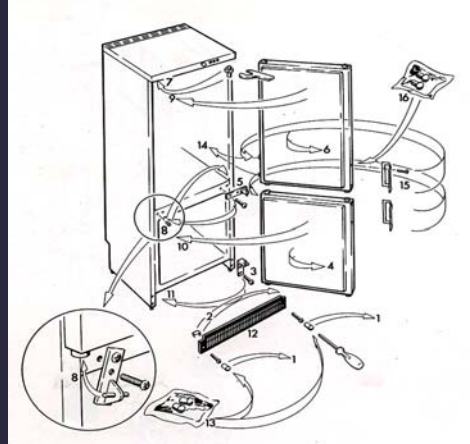
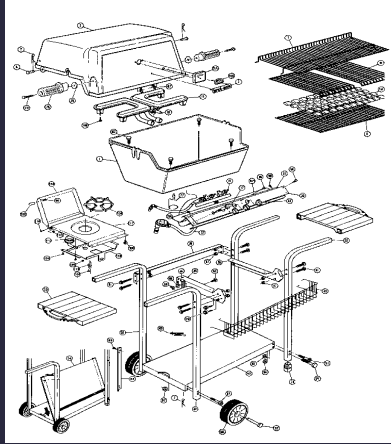

Previous Work

Planning

- Choose sequence of assembly operations
- Robotics / AI / Mechanical Engineering
[Wolter 89], [de Mello 91], [Wilson 92], [Romney 95]

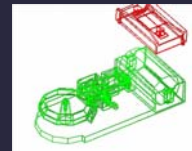

Presentation

- Visually convey assembly operations
- Visualization / Computer Graphics
[Seligmann 91], [Rist 94], [Butz 97], [Strothotte 98]



Jointly optimize plan and presentation

Geometric Analysis [Romney 95]

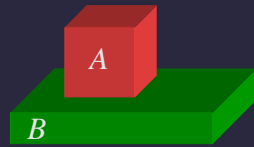

Input Parts

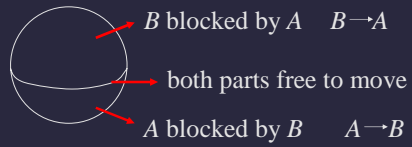

Blocking Graph

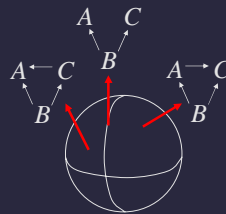
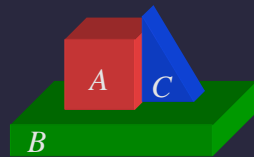

Geometric Assembly Planning

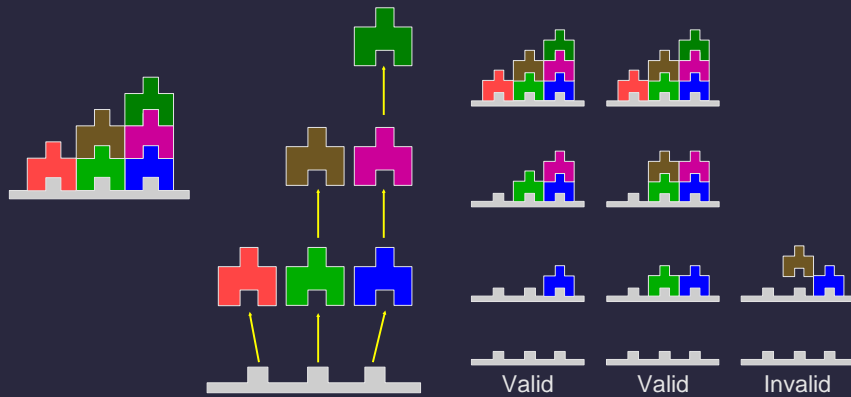

Many Geometrically Valid Sequences



How do we choose the best sequence?

Identifying Design Principles



Stage 1: Production

Stage 2: Preference

Stage 3: Comprehension

Spatial Ability Tests

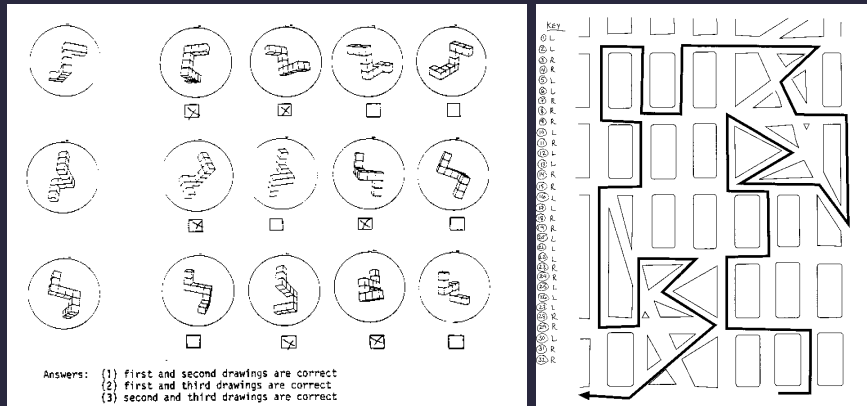

Mental Rotation [Vandenburg 78]

Navigation [Money 78]

Separate high and low spatial ability

Stage 1: Production



- 43 Participants
- Assemble TV Stand without instructions
- Write instructions for novice assembler

Stage 1: Mean completion time

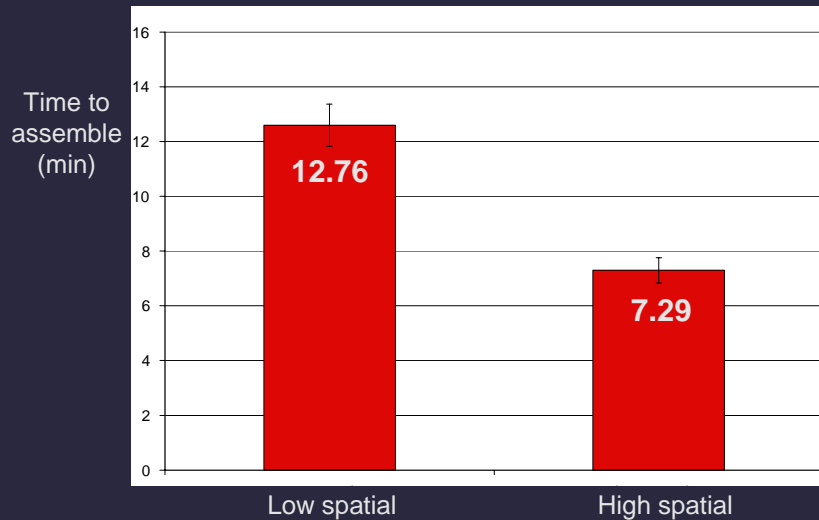

Stage 1: Instructions produced

First connect one side with the bottom shelf. Make sure that the two holes at the top of the side are facing inward. Also make sure that the two sides of the bottom shelf are wheels.

Next connect the other side with the bottom shelf. Again make sure the holes are facing inward.

Next connect the support to the sides using the 4 cable connectors.

Next connect the top shelf to the sides using the remaining screws.

Finally, attach the casters to the sides of the bottom.

- Place the side piece perpendicular to the other side of the previously assembled stand. The piece will go into the holes on the base piece. Screw the 2nd side piece to the base piece.
- Insert two plastic caps into holes in the inside side of the second side piece & slide base piece into caps.
- Now screw the 4th and 5th screws into the side pieces. Level with screw holes. Screw the screws into the holes of the side pieces that are back up 2 screws per side.
- Put stand over & level with extension appliances.

Insert wheels into holes in the two side pieces.

h1, h2, h3, o, o, s, f

- Almost all contained diagrams 98%
- Text redundant with diagrams 62%

Stage 1: Errors in instructions

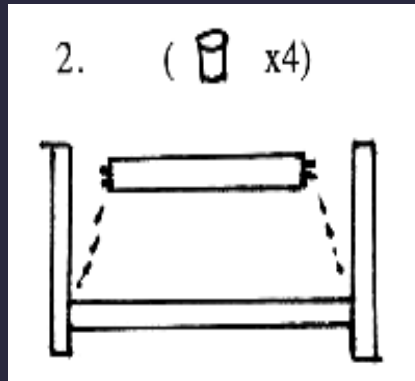

- Errors in low spatial instructions 86%
- Errors in high spatial instructions 12%

Stage 1: Errors in instructions

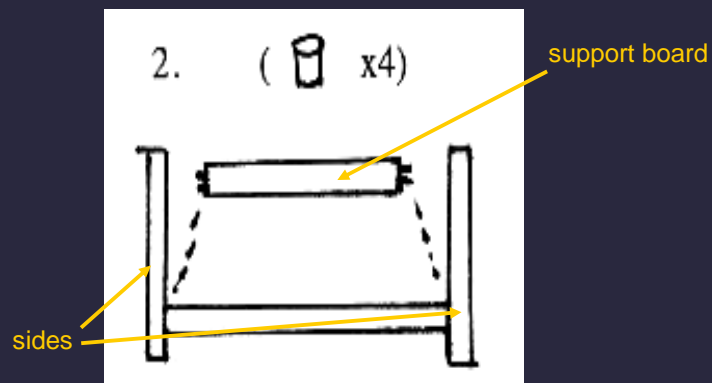

- Errors in low spatial instructions 86%
- Errors in high spatial instructions 12%

Stage 1: Classes of Diagrams

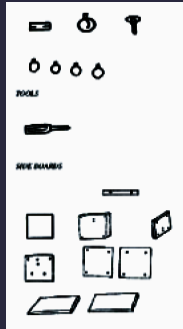

Parts menu

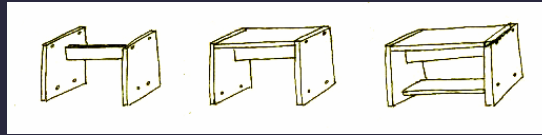

Structural diagrams

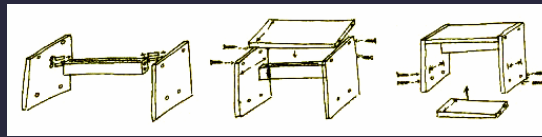

Action diagrams



- Parts menu to differentiate parts
- Structural diagrams depict completed step
- Action diagrams show assembly action/operation

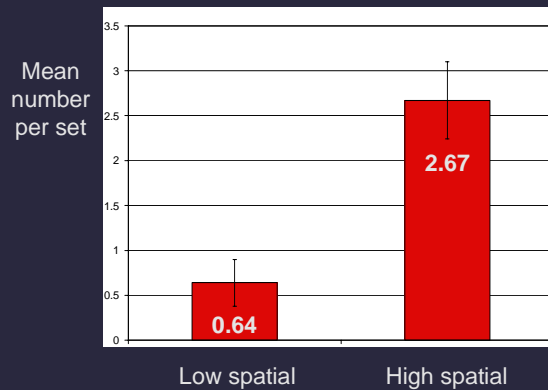

Stage 1: Action diagrams

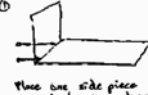
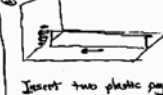

- High spatial
 - More action diagrams
 - More 3D diagrams
 - Less text



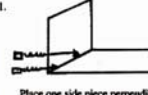



Stage 2: Preference

 <p>Place one side piece perpendicular to work surface & screw to top shelf piece.</p>	 <p>Insert two plastic pegs into holes in the inside side of the work surface & slide brace piece onto pegs.</p>
<p>Slide the 2nd side piece onto the other side of partially assembled stand. The pegs will go into the holes on the brace piece. Screw the 2nd side piece to shelf.</p>	<p>Have somebody hold smaller shelf between the two side pieces level with screw holes. Screw the screws into the holes of the side pieces that are lined up. 2 screws per side.</p>
 <p>Insert wheels into holes in the two side pieces.</p>	<p>Flip stand over & garnish with entertainment appliances.</p>

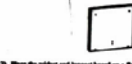
 <p>Place one side piece perpendicular to work surface & screw to top shelf piece.</p>	 <p>Insert two plastic pegs into holes in the inside side of the screwed side piece and slide brace piece onto pegs.</p>
<p>Insert other set of pegs into second side piece and slide the second side piece onto the other side of partially assembled stand. The pegs will go into the holes on the brace piece. Screw the second side piece to top shelf piece.</p>	<p>Have somebody hold smaller, lower shelf between the two side pieces, level with screw holes. Screw the screws into the holes of the side pieces that are lined up; 2 screws per side.</p>
 <p>Insert wheels into holes in the two side pieces.</p>	<p>Flip stand over and garnish with entertainment appliances.</p>

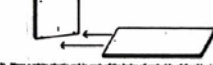
- 21 Participants
- Assemble TV Stand without instructions
- Rated 39 sets of redrawn instructions

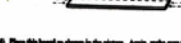
Stage 2: Highest Rated

<p>1) Stand the following board up as shown in the picture. (You should have two of these boards, but use only one for now.)</p> 	<p>2) Take the remaining long board and screw it to the boards. Make sure reinforced surface faces up and the edges that were attached to the other board.</p> 
<p>3) Place the widest and longest board on a flat surface such that the reinforced surface faces up and the long hole on one of the sides faces up with the bottom edge of the flat board as shown in the picture. (This way the reinforced edge of both boards face the same direction.)</p> 	<p>4) Place the remaining board and then it up such that all of its holes face up. Be sure the boards together.</p> 
<p>5) Place a white plastic rail in each of the holes of each side of the shorter board.</p> 	<p>7) Place the wheels into the holes as indicated in the picture and then flip the unit over.</p> 
<p>6) Place this board on plates for the plates. Again, make sure the reinforced surface also faces the same direction as the bottom edge of the other boards.</p> 	

- Ratings similar across all participants
- Spatial ability does not affect preference

Stage 3: Comprehension

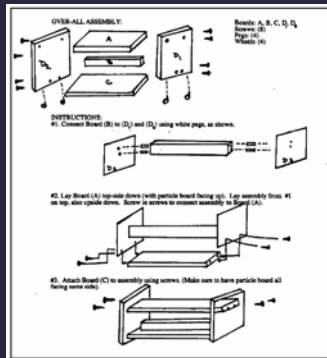

Set 1: Text + Action

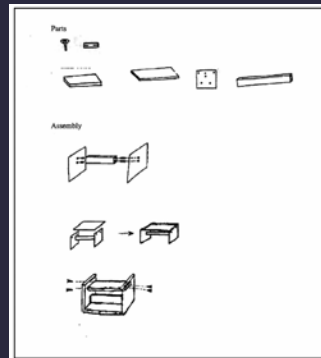

Set 3: Parts menu + Structural + Action

- 44 Participants
- Given 1 of 4 instruction sets from Stage 2
- Assemble TV stand using instructions

Stage 3: Results

- No difference in assembly time by condition
- Instruction consultations: Low 8.9 High 7.1
- Box picture consultations: Low 9.1 High 3.4

Comments

- Should show relevant parts and attachments
- Structural diagrams and exploded view hard to use
- Text not very useful

Design Principles

Step-by-Step
Action diagrams
Good visibility

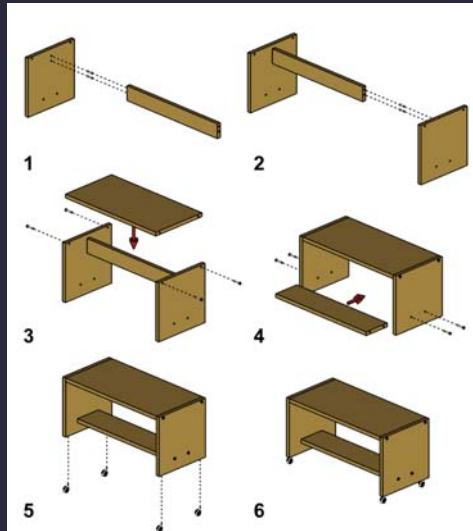

TV stand instructions generated by our system

Input

Geometry: Parts in assembled configuration

Orientations: Default viewpoint / orientation

Preferred orientation for each part

Groupings: Fasteners, significant parts, similar actions, symmetry

required
optional



Assembled geometry in default orientation

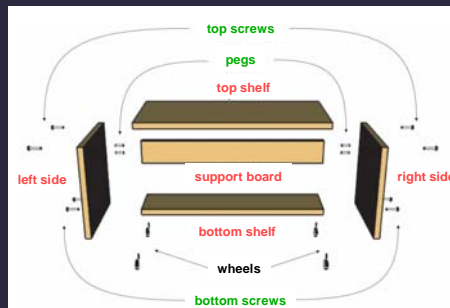

Parts grouped as fasteners and significant parts

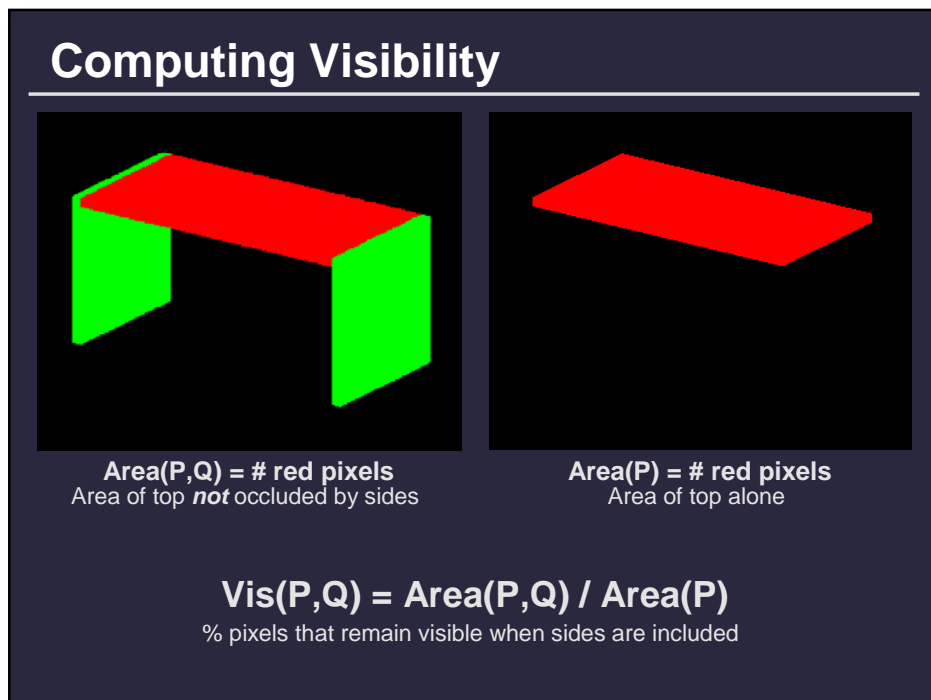
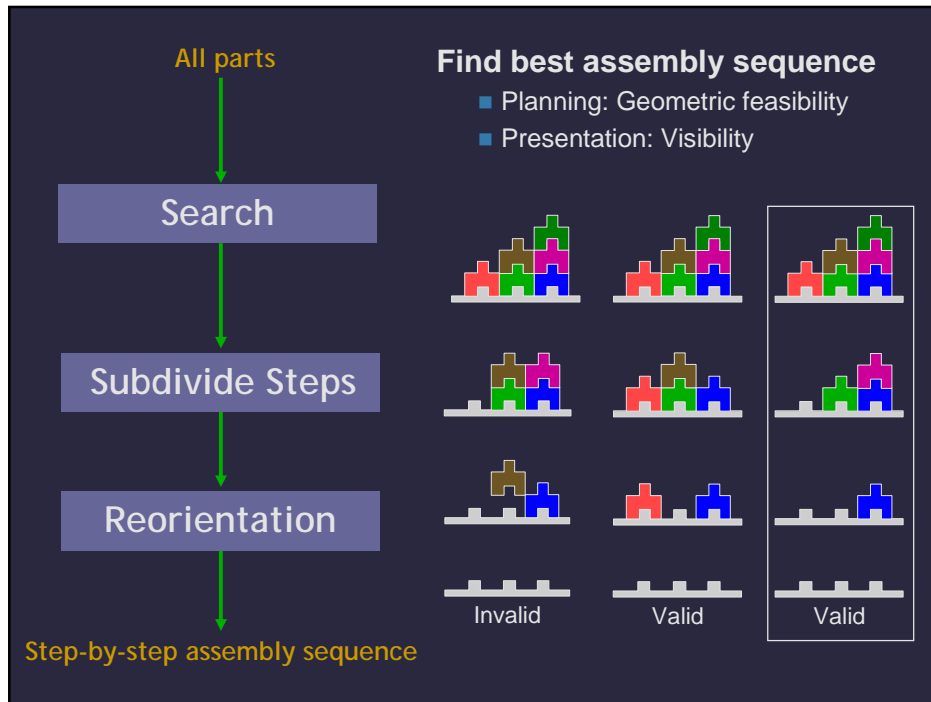

Visibility Constraints

1. Parts being attached R

- Check that each part is visible

$$\min_{r \in R} (\text{Vis}(r, R-r)) * W_R$$

2. Previously attached parts A

- Check that context is visible

$$\text{Vis}(A, R) * W_A$$

3. Future unattached parts U

- Check that future parts will be visible

$$\min_{u \in U} (\text{Vis}(u, R)) * W_U$$

Lego Car

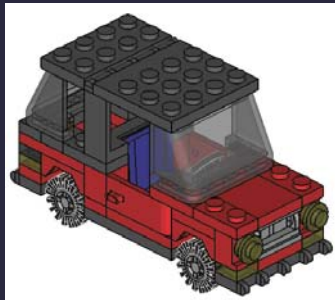

Input model

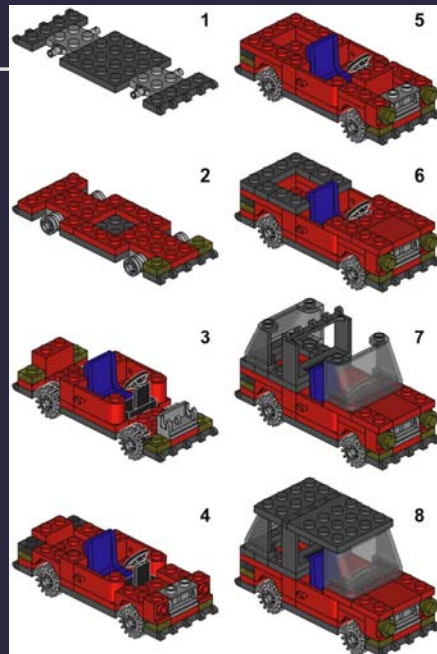

Bookcase



Input model

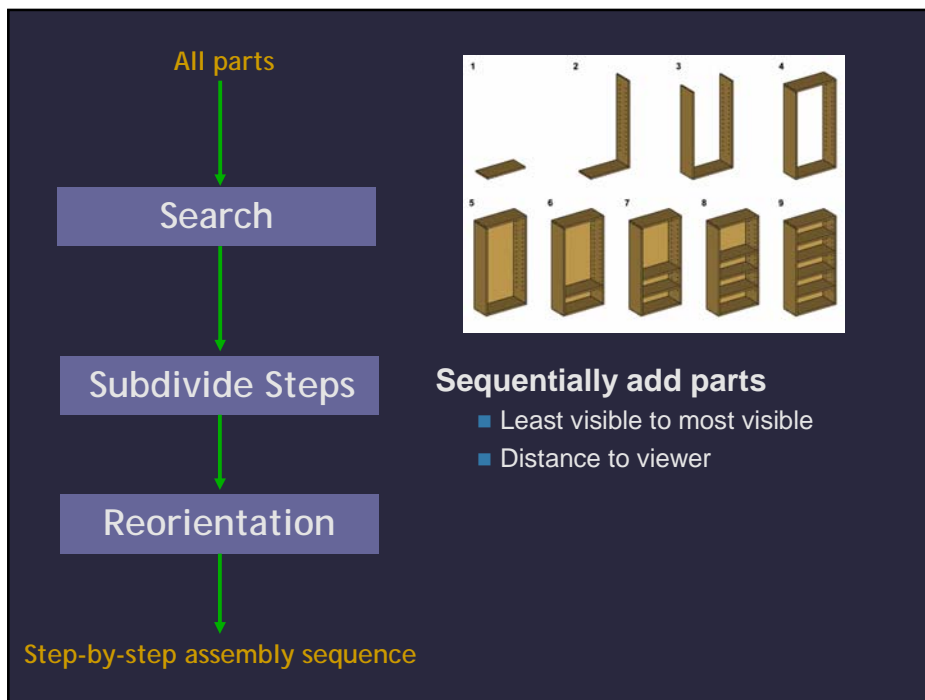
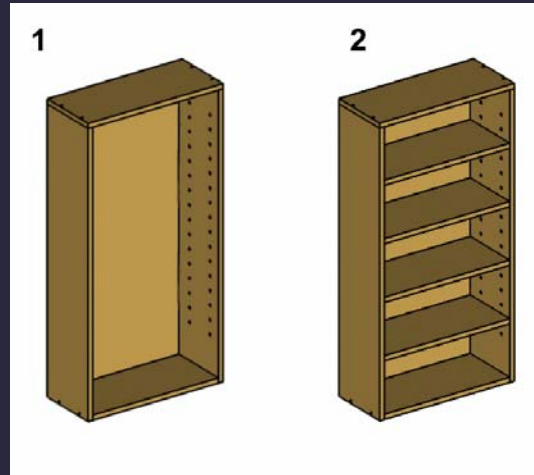

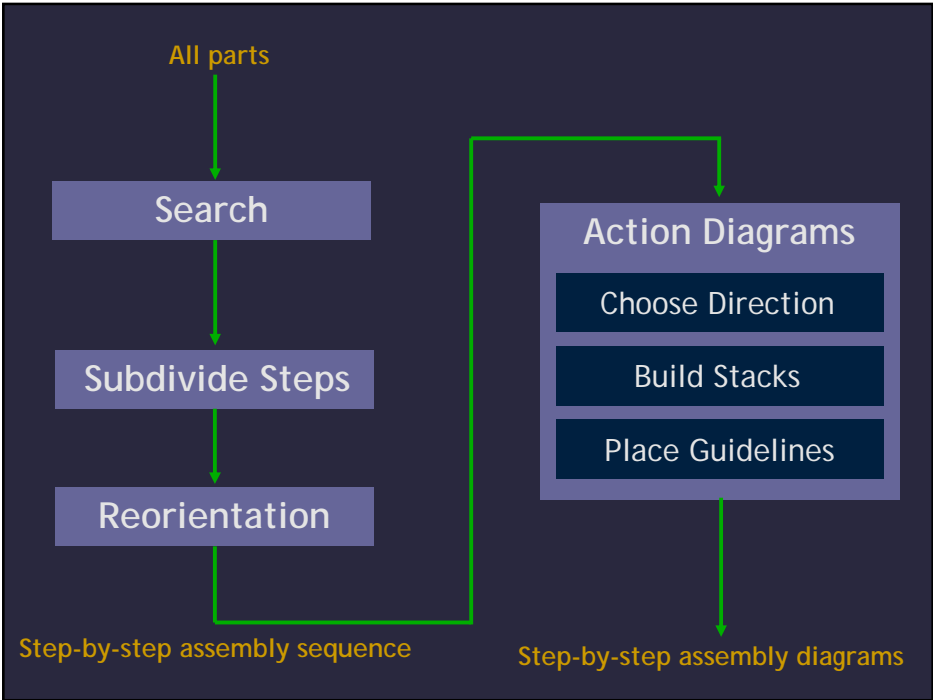
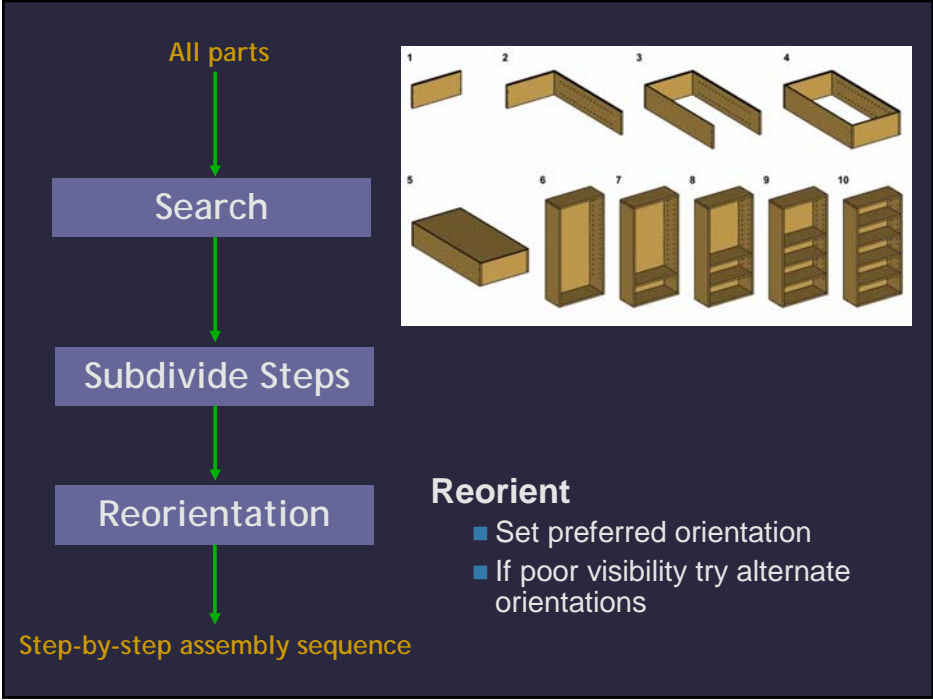

Bookcase

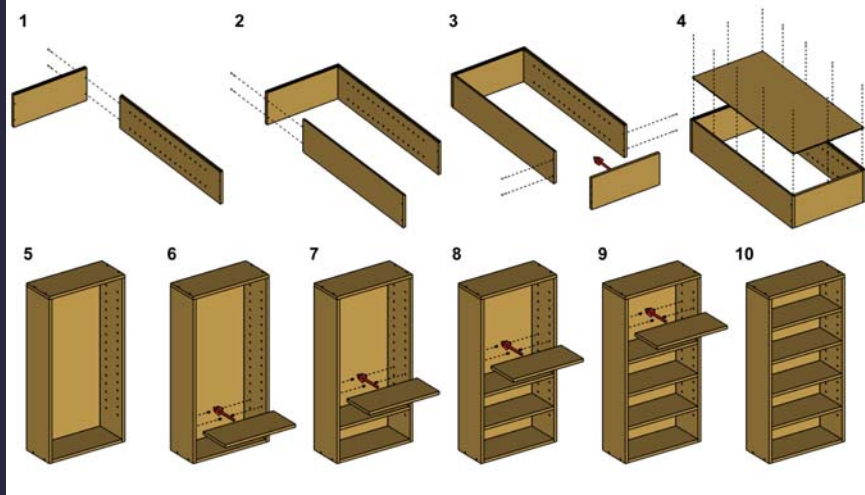

9 Parts

Design: 48s

Test Object

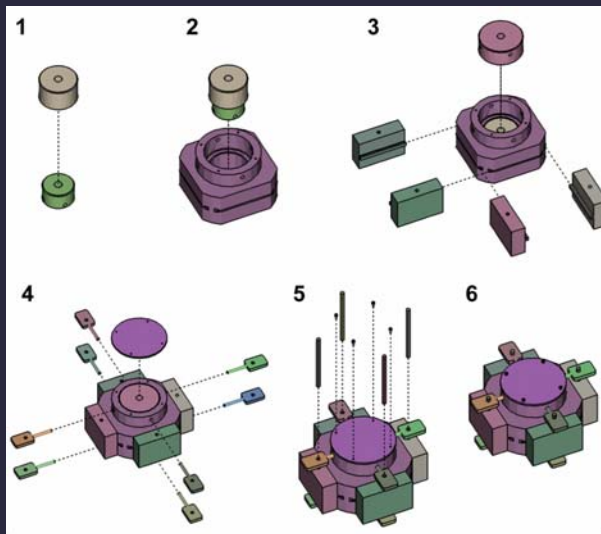

25 Parts

Design: 53s